



SERVICE PARTS LIST

BULLETIN NO.
54-40-5183

SPECIFY CATALOG NO. AND SERIAL NO. WHEN ORDERING PARTS		REVISED BULLETIN	DATE
SAWZALL®		54-40-5182	June 2007
CATALOG NO.	6519-22	WIRING INSTRUCTION	
	STARTING SERIAL NO.	58-01-0279	
	A18D		

FIG.	PART NO.	DESCRIPTION OF PART	NO. REQ.
1	06-82-2390	8-32 x 1-1/4" Slotted Pan Hd. T-20 Screw	(2)
2	06-82-7270	8-16 x 5/8" Pan Hd. Plastite T-20 Screw	(5)
3	31-44-1680	Left and Right Handle Halves	(1)
4	06-82-7240	6-19 x 1/2" Pan Hd. Slit. Plastite T-15 Screw	(2)
5	22-22-1385	Brush Holder Assembly	(1)

EXAMPLE:
Component Parts (Small #)
Are Included When Ordering
The Assembly (Large #).

★ = Part number change from
previous service parts list.

**SEE REVERSE SIDE FOR
IMPORTANT SERVICE NOTES**

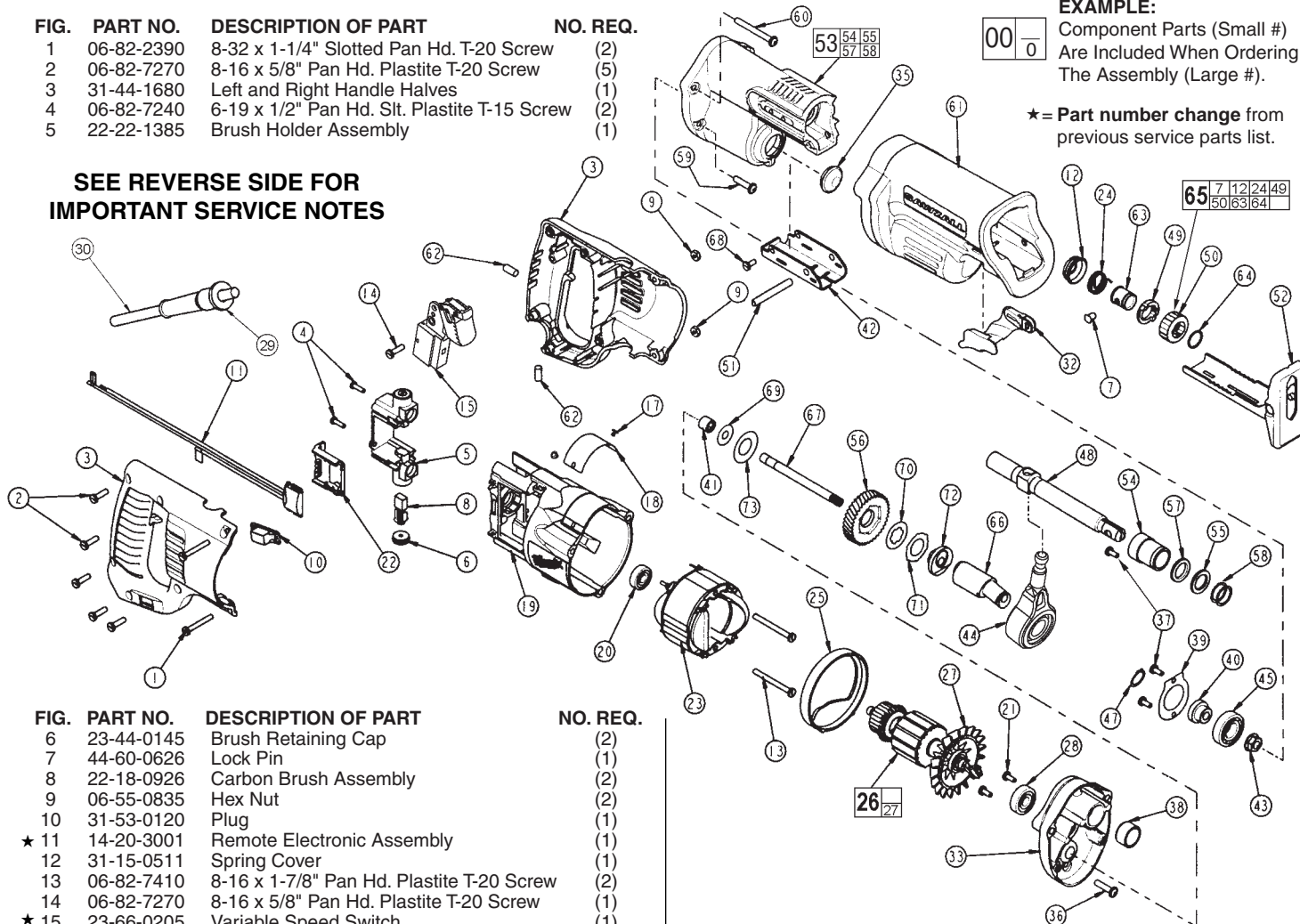

FIG.	PART NO.	DESCRIPTION OF PART	NO. REQ.
6	23-44-0145	Brush Retaining Cap	(2)
7	44-60-0626	Lock Pin	(1)
8	22-18-0926	Carbon Brush Assembly	(2)
9	06-55-0835	Hex Nut	(2)
10	31-53-0120	Plug	(1)
★ 11	14-20-3001	Remote Electronic Assembly	(1)
12	31-15-0511	Spring Cover	(1)
13	06-82-7410	8-16 x 1-7/8" Pan Hd. Plastite T-20 Screw	(2)
14	06-82-7270	8-16 x 5/8" Pan Hd. Plastite T-20 Screw	(1)
★ 15	23-66-0205	Variable Speed Switch	(1)
17	06-72-1720	Nameplate Rivet	(2)
18	12-99-1765	Service Nameplate	(1)
19	31-50-0020	Motor Housing	(1)
20	02-04-0845	Ball Bearing	(1)
21	06-82-7253	8-32 x 3/8" Pan Hd. Slit. Taptite T-20	(2)
22	43-72-0176	Heat Sink Holder	(1)
23	18-31-0510	120 V. Field	(1)
24	40-50-0161	Torsion Spring	(1)
25	31-05-0055	Baffle	(1)
26	16-30-0580	120 V. Armature	(1)
27	22-84-0531	Fan Assembly	(1)
28	02-04-0915	Ball Bearing	(1)
29	44-76-0210	Cord Protector	(1)
30	22-64-0495	Cord Set	(1)
32	31-52-0090	Shoe Release Lever	(1)
33	28-28-1000	Diaphragm	(1)
35	42-52-0380	Bearing Cap	(1)
36	05-88-8309	K50 x 35mm Round Washer Hd. PT T-20	(1)
37	06-82-7253	8-32 x 3/8" Pan Hd. Slit. Taptite T-20	(3)
38	42-24-0620	Rear Spindle Bearing	(1)
39	44-86-0055	Bearing Retainer	(1)
40	45-36-1445	Spacer	(1)
41	02-50-2150	Needle Bearing	(1)
42	44-66-0880	Shoe Retainer	(1)
43	06-55-3790	5/16-24 Spinlok Hex Nut	(1)
44	14-67-0135	Wobble Plate Assembly	(1)
45	02-04-1510	Ball Bearing	(1)
47	34-60-1315	Retaining Ring	(1)
48	38-50-0680	Reciprocating Spindle	(1)

FIG.	PART NO.	DESCRIPTION OF PART	NO. REQ.
49	42-50-0077	Rear Cam	(1)
50	42-50-0076	Front Cam	(1)
51	44-60-1635	Shoe Pin	(1)
52	45-16-0645	Shoe Assembly	(1)
53	28-14-0996	Gear Case	(1)
54	-----	Front Spindle Bearing	(1)
55	-----	Felt Seal	(1)
56	32-40-2050	Intermediate Gear	(1)
57	-----	Seal	(1)
58	-----	Washer	(2)
59	06-82-5363	8-32 x 1" Washer Hd. Taptite T-20	(2)
60	05-88-0302	K50 x 60mm Round Washer Hd. PT T-20	(2)
61	45-12-0999	Gear Case Insulator	(1)
62	14-46-1001	Foam Slug Kit - 10 Slugs	(1)
63	45-22-0081	Sleeve	(1)
64	34-60-3680	External Retaining Ring	(1)
65	14-46-1011	Steel Quik-Lok Blade Clamp Kit	(1)
66	36-92-0501	Wobble Shaft	(1)
67	42-12-0155	Wobble Shaft Axel	(1)
68	06-82-7253	8-32 x 3/8" Pan Hd. Slit. Taptite T-20	(1)
69	45-88-1555	Washer	(1)
70	43-06-0685	Metal Plate	(1)
71	43-06-0676	Bronze Disc	(1)
72	43-78-0525	Drive Hub	(1)
73	40-50-8850	Disc Spring	(1)

FIG.	LUBRICATION
53	Place 1/2 oz. of type "Y" grease, No. 49-08-5270, in gearing cavity near diaphragm.
53	Place 2-1/2 oz. of type "L" grease, No. 49-08-4175, in cavity in front of bearing plate.
FIG.	NOTES
20	Seal side faces commutator.
20,28,41,45	Press bearings to shaft shoulders.
33,38	Press rear spindle bearing flush to -.030 from front exterior face in diaphragm boss.
43	Torque to 180 in./lbs. to 210 in./ lbs.
33,41	Needle bearing is to be pressed from the open end flush to -.015 to face of bearing boss of diaphragm.
62	After routing wires, place one foam slug in each location shown on the front page. Center slugs on screw bosses and push down until flush with top of handle half.

REMOVING THE STEEL QUIK-LOK® BLADE CLAMP

- Remove external retaining ring (64) and pull front cam (50) off.
- Pull lock pin (7) out and remove remainder of parts and discard.

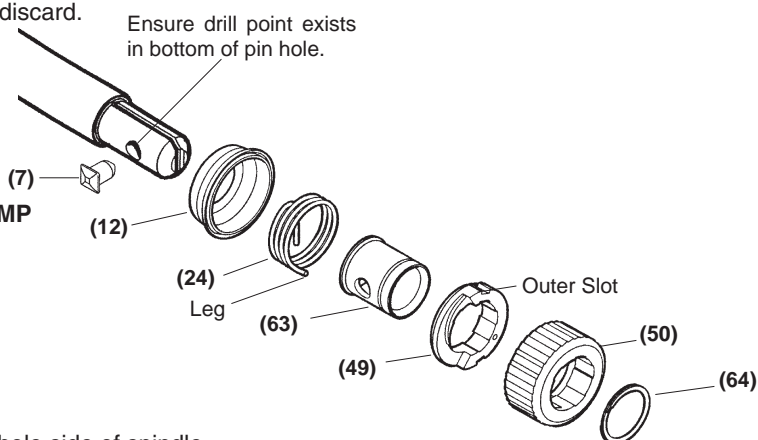

REASSEMBLY OF THE STEEL QUIK-LOK® BLADE CLAMP

- Coat new lock pin with powdered graphite.
- Hold tool in a vertical position.
- Place spring cover (12) onto spindle.
- Slide torsion spring (24) onto spindle with spring leg on hole side of spindle.
- Slide sleeve (63) onto spindle aligning hole on sleeve with hole in spindle.
- Slide rear cam (49) over sleeve until it bottoms on sleeve shoulder, ensure spring leg inserts into hole in rear cam.
- Rotate rear cam in the direction of the arrows located on spring cover until there is clearance for lock pin (7) to be inserted into sleeve/spindle holes. Insert lock pin.
- Align front cam (50) inner ribs with rear cam outer slots and slide front cam onto sleeve until it bottoms. Retaining ring (64) groove should be completely visible.
- Attach retaining ring by separating coils and inserting end of ring into groove, then wind remainder of ring into groove. Ensure ring is seated in groove.
- Blade clamp should rotate freely. During normal usage, debris may not allow blade clamp to rotate freely. The use of spray lubricant can help free blade clamp. In extreme conditions, follow these instructions to remove, clean and reassemble blade clamp.